



# HOW CAN BLUETOOTH® TECHNOLOGY ENABLE DIGITAL TRANSFORMATION ACROSS THE INDUSTRIAL IoT?



Andrew Zignani,  
Senior Research Director

## INTRODUCTION

Industrial enterprises are facing a growing number of economic, political, supply chain, regulatory, labor, and technology-related challenges. Recent years have been marked by various large-scale headwinds, including ongoing trade disputes, periodic lockdowns around the world, and the ongoing conflict in Ukraine. Inflation and increasing energy and transportation costs have also strained margins and impacted demand, while wider supply chain issues have affected the availability of products and components required for production and getting finished products to customers. In addition, new regulations require industrial environments to operate much more safely, have more stringent compliance procedures, and function more sustainably, while difficulties in attracting and retaining new personnel make it more vital than ever to improve staff efficiency and processes, while creating safe and satisfying work environments.

These factors are all leading industrial enterprises to invest more in digitalization, with a view to enabling enhanced supply chains and asset visibility, improved and automated compliance, optimization of labor resources and increased automation, improved yields through enhanced Quality Assurance (QA) and error avoidance, and wider process optimization via digital twins, mixed reality, and Machine Learning (ML). This is giving enterprises greater visibility of their entire operations and driving new efficiencies, while firms further along the digital transformation process can deal more readily with both today's and future challenges.

### CONTENTS

- Introduction ..... 1
- Industrial Use Cases for Bluetooth® Technology ..... 5
- Market Opportunities for Industrial Bluetooth® ..... 14
- Key Requirements for Industrial Bluetooth® ..... 15
- How Is Infineon's Bluetooth® Technology Enabling the IIoT to Reach Its True Potential? ..... 17
- Key Takeaways ..... 22

Fundamental to this digital transformation is the wide range of wireless Internet of Things (IoT) devices capable of providing real-time insights into industrial operations. This encompasses wireless infrastructure, IoT gateways, control panels, and a diverse range of wireless end-node devices, each with unique requirements. These end nodes include wireless sensors, asset tracking tags, wearable devices, robotics, Automated Guided Vehicles (AGVs) and drones, smart meters, networked lighting nodes, beacons and Electronic Shelf Labels (ESLs), video surveillance cameras, connected tools, Human-Machine Interfaces (HMIs) and scanner devices, access control readers, Electric Vehicle (EV) chargers, and Point of Sale (POS) terminals, among many others. The heterogeneous nature of these IoT devices means that there is a diverse, sometimes contradictory, set of performance requirements for each. To give a few examples, some devices will require high-speed multi-Gigabits per Second (Gbps) throughput at very low latencies, while others will transmit a few Kilobits per Second (Kbps) of data just a few times a day. Some devices will be mains powered or have large batteries, while others will rely on coin-cell operation and require months to years of battery life. Some devices will be in close proximity to a gateway or Access Point (AP), while others may operate at extended distances of up to 1 Kilometer (km) or more. Some may be deployed within harsh industrial environments, while others may operate outdoors. Some devices may be fixed, while others may be highly mobile. Some devices may be deployed sparsely, while others may be deployed in dense, congested environments with thousands of other end nodes in close proximity.

---

**Multiple technologies, including Wi-Fi, Bluetooth®, 802.15.4, and Ultra-wideband (UWB), will play unique roles within the transformation of these commercial and industrial environments.**

---

It is perhaps unsurprising then that a single wireless connectivity technology is incapable of addressing all of the requirements of each device effectively. Multiple technologies, including Wi-Fi, Bluetooth®, 802.15.4, and Ultra-wideband (UWB), will play unique roles within the transformation of these commercial and industrial environments. Furthermore, even within a single wireless technology, the diverse requirements of each use case will likely require tailored connectivity solutions that can address some of the unique deployment problems that each product type will face. For example, specialized solutions that can provide extended range, ultra-low power consumption, the ability to perform in greater temperature ranges, greater robustness, higher-throughput modes, unique topologies, or a combination of these, will be critical to ensuring that the Industrial IoT (IIoT) markets can reach their true potential over the next decade.

Maximizing industrial digital transformation also depends on the continued innovation and evolution of Short-Range Wireless (SRW) connectivity technologies. Future use cases will demand additional improvements across almost all metrics—including throughput, latency, robustness, reliability, power consumption, range, security, scalability, efficiency, size, cost, interoperability, flexibility, and deployment density. It will also require wireless portfolios that can take advantage of the unique benefits of each technology via combo and multi-protocol Systems-on-Chip (SoCs) and modules. More stringent requirements at both ends of the performance spectrum may require additional work in the standards development process to ensure meeting all of the diverse demands. Combined, these enhancements will enable SRW technologies to improve performance in existing use cases, open new market opportunities, and lead to developing new operational efficiencies and user experiences across multiple industrial verticals. One technology that is continually innovating to solve industrial pain points is Bluetooth®.

This paper highlights the growing opportunities for Bluetooth® technology within industrial applications. First, it discusses how the continuous evolution of Bluetooth® is enabling the technology to better target this market. Second, it highlights how Bluetooth® technology is being leveraged across a range of environments, including industrial manufacturing, commercial buildings, smart energy, smart retail, Real-Time Location Systems (RTLs) and asset tracking,

and other IIoT applications. Third, it provides high-level forecasts for Bluetooth® technology within these segments. Finally, it discusses the key requirements of enterprise connectivity, and highlights how flexible, wireless portfolios from leading connectivity solution providers such as Infineon are capable of addressing the specific stringent needs of the industrial landscape, and why these solutions will be critical in ensuring the market reaches its true potential over the next decade.



## The Evolution of Bluetooth® Technology for Industrial Applications

Bluetooth® technology has several inherent benefits for industrial applications. This includes resilience to interference and robustness, ultra-low power consumption via Bluetooth® Low Energy (LE), wide availability of low-cost chipsets and modules, a ubiquitous presence in mobile and computing devices, a strong presence in enterprise wireless infrastructure and IoT gateways, support for multiple topologies, accurate positioning, and secure ranging capabilities, and an active standards development group that continues to innovate to deliver interoperable, scalable solutions that can address the diverse requirements of enterprises.

There are two main types of Bluetooth® technology: 1) Bluetooth® Basic Rate/Enhanced Data Rate (BR/EDR), also known as Bluetooth® Classic; and 2) Bluetooth® LE, both of which operate in the 2.4 Gigahertz (GHz) unlicensed Industrial, Scientific, and Medical (ISM) band. Bluetooth® Classic is a point-to-point technology that supports a maximum data rate of 3 Mbps when using the EDR PHY, and was primarily used as an audio streaming technology to enable wireless headphones and speakers, automotive infotainment systems, and file transfer between devices. Power consumption is relatively high at approximately 1 Watt (W). In contrast, Bluetooth® LE, first arriving in 2010, is a continually evolving low-power (between 0.01 W and 0.5 W) Bluetooth® technology that supports multiple topologies and additional features such as positioning capabilities. Depending on the specific operation mode, Bluetooth® LE can support data rates of up to 2 Mbps.

Over time, Bluetooth® LE has continued to improve performance and add new features to better target new enterprise markets. New topologies such as broadcast functionality have enabled the technology to target beacon and RTLS applications, while Bluetooth® 5.0, introduced in 2016, brought support for 2 Mbps throughput to Bluetooth® LE, alongside a 4X range increase and an 8X increase in data broadcasting capacity. The arrival of Bluetooth® mesh in 2017 enabled the technology to better address commercial lighting and large-scale sensor network applications.

Bluetooth® 5.1 in 2019 brought Direction Finding, enabling support for Angle of Arrival (AoA) and Angle of Departure (AoD) positioning techniques to provide much higher accuracy location services compared to previous Received Signal Strength Indicator (RSSI) methods. Meanwhile, upcoming support for Bluetooth® Channel Sounding will add security and accuracy to Bluetooth's positioning capabilities, taking advantage of secure ranging-based applications within RTLS, personal tracking, and access control, among others. In early 2023, the Bluetooth® Special Interest Group (SIG) announced the release of a new wireless standard for the ESL market, leveraging key new feature enhancements introduced in Bluetooth® Core Specification Version 5.4, including Periodic Advertising with Responses (PAwR) and Encrypted Advertising Data, to deliver secure, low-power, and scalable connectionless deployments required by the ESL market. As Figure 1 shows, PAwR can also enable more scalable, bidirectional one-to-many Bluetooth® deployments for a range of IoT asset tracking and sensor networks. Most recently, in September 2023, the Bluetooth® SIG made available its full stack standard for Networked Lighting Control (NLC) applications, making it easier to develop interoperable, scalable commercial smart lighting solutions.

**Figure 1: The Evolution of Bluetooth® Advertising**

Source: Infineon

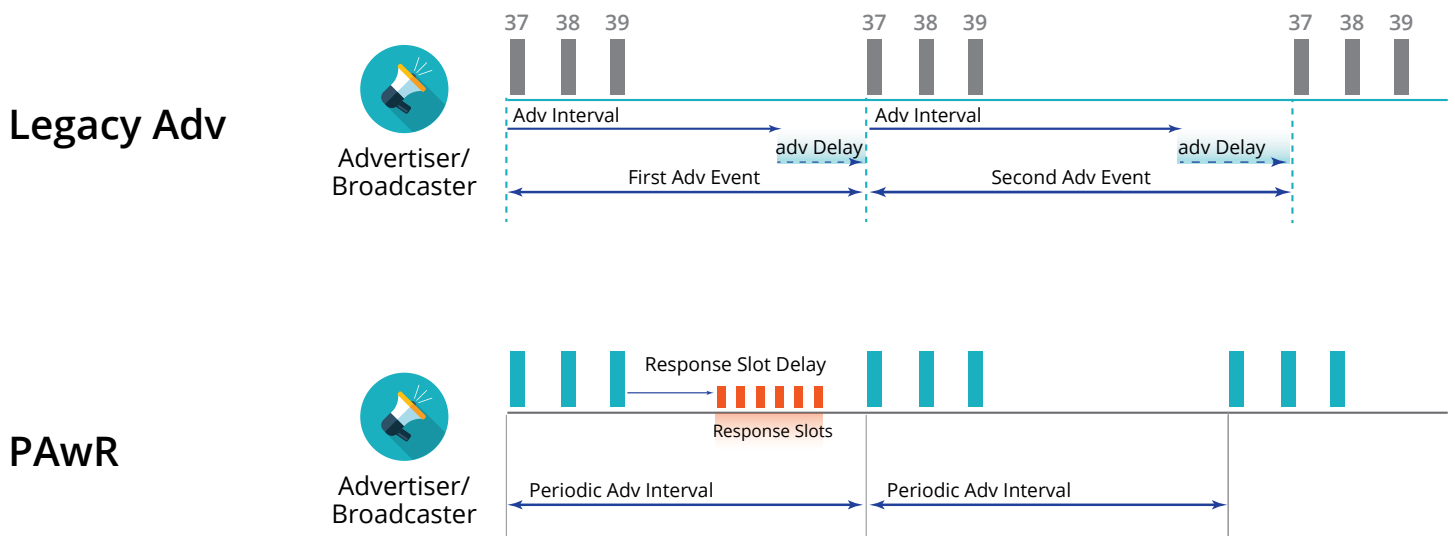

Beyond the standard development process within the Bluetooth® SIG, there is an enormous ecosystem of Bluetooth® solution providers offering tailored solutions to address specific market verticals. Within the industrial space, market leaders such as Infineon continue to innovate and evolve their Bluetooth® portfolios in order to meet the evolving demands of enterprises. This can include increased reliability and robustness, high throughput modes, scalable mesh, and one-to-many topologies, alongside extended range and extended temperature support. Combined, these innovations show the growing capabilities of Bluetooth® and are making the technology more attractive than ever before in enabling a range of IIoT use cases.

Compared to other technologies such as Zigbee or proprietary 2.4 GHz solutions, Bluetooth® offers a number of advantages. These include the ubiquitous presence in mobile devices and a wide presence in wireless infrastructure, the ability to provide higher data rates, support for multiple topologies and connectionless deployments, audio capabilities, ultra-low power consumption, strong interoperability, low cost, and strong backing from a wide vendor ecosystem driving further technical innovations. It can also be readily integrated with other technologies to bring unique solutions that take advantage of the benefits of each.



## INDUSTRIAL USE CASES FOR BLUETOOTH® TECHNOLOGY

The monitoring of industrial assets across the factory floor, warehouse, or logistics operations is becoming increasingly vital in ensuring and increasing the efficiency, reliability, safety, and productivity of a facility. In an increasingly competitive landscape, facility owners must turn to new technologies to accelerate this development and continue to increase performance, with the focus increasingly shifting toward monitoring assets previously never monitored in order to drive new efficiencies. Wireless solutions can be deployed where wired connectivity solutions are too costly, time consuming, complicated, or hazardous. Alongside manufacturing and logistics environments, one of the fastest growing IoT segments is the commercial building automation market. The convergence of environmental necessity, technical viability, falling costs, new IoT solutions, and greater expectations from buildings, offices, campuses, and other urban environments is driving growth in wireless smart building technologies. Incorporating connected technologies can lead to reduced energy consumption, reduced operating and maintenance costs, increased life span of commercial equipment, increased tenant health, comfort, and satisfaction, increased productivity, and improved security, resilience, and safety. This includes Heating, Ventilation, and Air Conditioning (HVAC) control, NLC, access control, and the aforementioned wireless sensor networks. Infineon's portfolio of robust, extended range solutions will be key in enabling reliable connectivity over large commercial building campus environments. Table 1 below provides a more in-depth comparison of the key wireless technologies for industrial applications.

	Best Suited Applications	Key Feature	Number of Semiconductor Suppliers	Data Rate	Typical (example) Rx/Tx current	Point-to-point Range	Standards Body
Wi-Fi 6	Security Cameras, Smart door locks	Data throughput	Multiple	Up to 9.6 Gbps	Rx <15mA Tx 150mA+	up to 35m	Wi-Fi Alliance
Bluetooth 5.4 BLE Mesh	Lighting and Building Automation	Multi-hop Number of nodes	Multiple	Up to 2 Mbps (depends on PHY configuration)	RX < 5 mA TX 3 - 5 mA @ 0 dBm	up to 6 km LOS (depends on PHY configuration)	Bluetooth SIG
Bluetooth 5.4 BLE Long Range	Indoor/Outdoor Asset Tracking	Long range	Few				
Bluetooth 5.4 BLE PAwR	Solar panels/farms, ESL, Wireless BMS	1-to-N control with short response latency					
IEEE 802.15.4 with Mesh networking Zigbee	Residential/Industrial LED Lighting, Smart Home, Sensors	Application interoperability, Mesh networking	Many	250 kbps	RX < 2.5-5 mA TX 20 mA @ +10 dBm TX >90 mA @ 20+ dBm (US)	up to 90 m	Connectivity Standards Alliance (CSA)
IEEE 802.15.4 with Mesh networking Thread (with DALI+, KNX)	Industrial Building Automation	Application Standards Mesh networking IP					Thread Group, DALI Alliance etc.
IEEE 802.15.4 with Mesh networking Matter/Thread	Smart Home Speakers and connected devices	Application interoperability / Home Ecosystem					CSA, Thread Group
Proprietary Sub GHz	Variety / Fragmented	Flexibility and propagation	Many / Fragmented	Up to 100 kbps	RX < 5 mA TX 26 mA @ +14 dBm TX 90 mA @ 20 dBm	up to many kms (depends on PHY configuration)	Proprietary

Due to its unique characteristics and inherent flexibility, Bluetooth® technology is already being leveraged within a number of enterprise and industrial environments. Meanwhile, new Bluetooth® use cases that can solve specific industry pain points are emerging almost daily. While some of these may ultimately remain small scale, if one looks at virtually any aspect of enterprise and industrial operational pain points where an object needs to be tracked, the condition monitored, access provisioned, or an environment sensed, potential exists to leverage Bluetooth® as a connectivity solution. The following section highlights some of the major opportunities for Bluetooth® technology across these market sectors.

## Industrial Building Wireless Sensor Networks

Bluetooth® technology is increasingly being leveraged within a wide array of industrial sensors deployed on the factory floor. These sensors can monitor numerous variables, including temperature, humidity, vibration, pressure, flow, moisture, tilt, and acoustics, to monitor the condition and perform advanced analytics of industrial equipment, including motors, pumps, fans, storage tanks, gearboxes, etc. The growing availability of wireless industrial sensors enables a new range of previously unconnected and unmonitored devices to share information and use predictive and preventative maintenance to ensure smoother and safer operations, increase performance, ensure regulation compliance, and reduce the risk of costly downtime. These sensors can be deployed in a wide range of environments, including industrial manufacturing, mining, utilities, commercial refrigeration, agriculture, etc.

---

**The growing availability of wireless industrial sensors enables a new range of previously unconnected and unmonitored devices to share information and use predictive and preventative maintenance to ensure smoother and safer operations**

---

These diverse deployment environments may require deploying sensors over large coverage areas, or in more remote areas where machinery is being monitored at some distance from the nearest AP or IoT gateway. They may also be deployed in harsh areas with strong potential for interference, or on equipment operating in very high or low temperature environments. Facilities may also want to equip hundreds or thousands of end nodes in a single area. Infineon's portfolio of Bluetooth® solutions with extended range capabilities, strong Radio Frequency (RF) performance, ultra-low power consumption, extended temperature range, and support for PAwR, are well placed to support scalable and reliable industrial sensor deployments, while minimizing deployment cost and complexity.

Smart buildings will also require the deployment of numerous battery-powered wireless sensor nodes to enable lighting, HVAC, security, access, and fire and safety services across a facility. Bluetooth® has the potential for use across a number of different device types and topologies.

Within HVAC, central controllers can communicate with Bluetooth® mesh-enabled wireless temperature, humidity, air quality, and occupancy sensors deployed throughout the building to ensure optimal energy usage. Wireless thermostats can also leverage Bluetooth® and communicate requirements back to an IoT controller based on user preferences. While other wireless building automation technologies also exist, Bluetooth® has the unique advantage of enabling direct communications between mobile devices, the controller, and sensor nodes. This can help with diagnostics, remote control, and device provisioning.

Alongside HVAC-related sensors, new sensor types are emerging thanks to the desire among building owners, tenants, and regulators for growing visibility of energy management, environmental monitoring, health and hygiene monitoring, building conditions, and utilization, as well as demands from building users to work in safer, cleaner, more flexible, and comfortable environments. This is being compounded by increased energy costs, high rental prices, sustainability goals, and a shift to hybrid and flexible working environments. These demands will open up new opportunities for a range of new Bluetooth® sensor devices that can monitor

new information or expand the granularity of existing use cases. This will include occupancy sensors, contact sensors, ambient light sensors, motion sensors, temperature sensors, leak sensors, feedback sensors, air quality sensors, and fire and smoke sensors, among others such as sound and gas. Infineon's support for the newly released features PAwR can help enable the synchronization of large numbers of end nodes, while minimizing power consumption, mitigating congestion and interference, and simplifying deployment.

New sensors and monitoring devices are also emerging to help better manage the operations of smart building environments. For example, waste bins, soap and hand towel dispensers can be equipped with sensors indicating when emptying or replenishment is needed. Bluetooth® LE and its support for mesh makes it a viable solution for scalable deployments of a range of wireless end nodes in commercial environments.



## Robotics

Another key opportunity for Bluetooth® in industrial environments is robotics. While many robots will require wired connectivity, growing opportunities exist for Wi-Fi and Bluetooth® to enable autonomous navigation, and robot-to-robot communication. The largest opportunity both from an adoption and market size perspective will come from mobile robots, including AGVs, Autonomous Mobile Robots (AMRs), and Collaborative Robots (cobots), that require mobility and flexibility. These can transfer position, load, battery level, and additional metrics when traveling through an industrial environment. In addition to navigating dynamic environments, having a direct Bluetooth® connection to a smartphone, tablet, or industrial HMI/Personal Computer (PC) can enable updating an AGV/AMR's tasks or routes at any time.



## Human-Machine Interfaces

HMIs in an industrial context refer to devices that allow humans to interact with machines. In industrial settings, HMIs are most commonly located next to, or built into machines. HMIs communicate with Programmable Logic Controllers (PLCs) and Industrial PCs (IPCs) to acquire and display information, supporting the management of Supervisory Control and Data Acquisition (SCADA) and Manufacturing Execution System (MES) solutions, alongside critical machine actions, such as switching machines on and off or increasing production speed. Industrial HMI devices have typically relied on physical connections such as serial ports. However, Bluetooth® technology allow operators to control industrial devices wirelessly, enabling smartphones, tablets, and PCs to display more intuitive User Interfaces (UIs) and simplify industrial equipment operation. This also helps reduce the cost of expensive physical interface components, save time and cost in educating end users on specific HMI systems, simplify maintenance and installation time and costs, increase deployment flexibility, and improve worker safety. Furthermore, broad portfolios from wireless vendors such as Infineon can help support the varied requirements of HMIs, including audio support and mobile device interaction.



## Industrial and Logistics Computing Devices, Scanners, and Wearables

Industrial computing devices including handheld barcode scanners or Radio Frequency Identification (RFID) readers, cold storage computers, hazardous environment computers, vehicle-mounted computers, and wearable devices are commonly used in enterprise environments' day-to-day operations. Most of these devices come equipped with both Wi-Fi and Bluetooth® to connect to peripheral devices such as portable or industrial printers, barcode scanners, headsets, etc., via a Bluetooth® or Bluetooth® LE connection.

Workers are also increasingly equipped with wearable scanners in smart manufacturing and warehouse environments to speed up and automate package scanning and component or assembly processes. As they typically scan hundreds of packages per day, using a handheld scanner that must be picked up and put down during each scan is not always efficient. Automating the process with wearable scanners that scan the barcode of a package as the user picks it can significantly increase worker productivity. Many scanning devices use Bluetooth® to communicate with another mobile computer such as a smartphone for datalogging, while some also incorporate Wi-Fi for standalone functionality.



## IIoT Gateways

While one benefit of Bluetooth® LE is that it is capable of connecting with smartphones and other mobile devices, many of these applications will require fixed IoT gateways with high-performance Bluetooth® technology that can monitor sensors, assets, and other equipment over long distances and in harsh environments. Support for Bluetooth® mesh and PAwR also enables more scalable sensor networks over large distances, making it more viable than ever for large-scale campus deployments.



## Smart Lighting

Smart lighting will be at the forefront of many smart building projects. The continued transition to Light-Emitting Diode (LED) luminaires can bring up to a 50% cut in a building's lighting energy consumption, which itself can account for up to 30% total energy usage within a building. Wireless connectivity is replacing wired as the best suited approach to delivering connected lighting into an emerging generation of smart buildings. Wireless addresses the key issues related to cost and minimal installation disruption in the retrofit market, which represents the largest overall opportunity. However, ease of maintenance and additional flexibility will further drive wireless in new build projects. Smart lighting can increase efficiency by adding automated and dynamic lighting control to LED systems. Combining lighting operation and management with sensors—most commonly, occupancy and natural lighting levels—can activate lighting as required.

Bluetooth® LE has continually improved performance and added new features to better target new markets. The standardization of Bluetooth® mesh in 2017 enabled the technology to increasingly target commercial lighting applications. Building on this, in 2023, the Bluetooth® SIG announced its first full stack standard for Bluetooth® lighting control, known as Bluetooth® NLC. This standardizes the radio layer, communication layer, and device layer, bringing standardized profiles for ambient light sensors, occupancy sensors, basic lightness, scene selection, dimming control, and energy monitoring. This has the potential to enable multi-vendor interoperability and will encourage much wider adoption of Bluetooth® mesh lighting in a wide range of commercial and industrial settings. In addition to sensor functionality, which can optimize lighting and energy savings based on occupancy and ambient lighting conditions, Bluetooth® lighting infrastructure can also act as a backbone network for location services via embedded beacons. This can include indoor navigation via smart devices, proximity services in retail applications, or asset tracking in commercial buildings, bringing valuable added services alongside potential quicker Return on Investment (ROI).



## Building Access Control

Another critical component of building automation is within access control. Thanks to Bluetooth's ubiquitous presence in mobile devices, the technology is increasingly being leveraged as a keyless entry technology within home and commercial building access. This allows users to leverage their smartphones, wearables, and Bluetooth® key fobs or badges to act as digital keys. Key benefits of deploying Bluetooth®-enabled access control readers include avoiding lost access cards and badges, increased security, tighter control, and lower deployment cost. Temporary access can be granted to visitors or delivery personnel without needing to provide them with physical key cards. Access can also be restricted to certain areas at certain times, or to a certain number of people, and revoked at any time, enhancing safety and security in emergency situations.

The arrival of Bluetooth® Channel Sounding also brings significant upgrades to the accuracy and security of Bluetooth® positioning and access control solutions. This makes it less susceptible to relay attacks and better suited to secure ranging and access applications, while continuing to offer low-power consumption. Furthermore, UWB-enabled access control solutions will also rely on Bluetooth® connectivity for handover purposes, or can increasingly leverage both technologies to support the greatest number of users. Other opportunities for in-building security include door and window locks equipped with Bluetooth® for perimeter monitoring in remote areas due to their low-power consumption.



## Asset Tracking, Real-Time Locating Systems, and Supply Chain Monitoring

The largest projected opportunity for Bluetooth® within IIoT applications can be found within RTLSs and asset tracking. A large and growing ecosystem of Bluetooth® location service providers are leveraging the technology to deliver increased productivity, improved staff and visitor safety and security, greater automation, reduced asset losses, and enhanced compliance and traceability. Opportunities for RTLS solutions can apply to virtually any enterprise setting. This includes not only industrial and warehouse facilities, but also healthcare settings, education campuses, transportation hubs, and retail environments, among others. Global enterprises can see tremendous cost savings through enhanced operational efficiencies, increased worker safety, and loss prevention, among other valuable use cases. The volume of assets that need tracking opens up enormous opportunities for Bluetooth® solution providers in the years to come.

Historically, RSSI-based Bluetooth® location solutions were capable of providing up to several meters of positioning accuracy, but Bluetooth® Core Specification Version 5.1 introduced Bluetooth® Direction Finding, enabling support for AoA and AoD positioning techniques to enable sub-meter, low-latency performance across several different environments. Meanwhile, the imminent arrival of Bluetooth® Channel Sounding will bring enhanced accuracy, security, and ranging capabilities without the need for complex antenna designs, helping to maintain the low-cost, low-power, and low-complexity advantages of Bluetooth® within accurate positioning applications. While alternative technologies such as UWB are also gaining traction within higher precision tracking applications, there is increasing desire for hybrid deployments and tags that can leverage the strengths of each technology to deliver scalable, high-performance RTLS deployments. The increasing availability of low-cost Bluetooth® tags makes it an extremely scalable solution across numerous environments.



## Asset, Material, Equipment, and Tool Tracking

Another opportunity for Bluetooth® technology in the industrial space is within connected tools. Whether deployed on the factory floor, construction sites, or within other enterprises, smart tools equipped with Bluetooth® have the potential to connect directly to a smartphone app or via a gateway to an MES to enable a number of valuable use cases. This includes monitoring the condition of tools for predictive and preventative maintenance, enhanced traceability, and quality assurance via automated logging of measurement and other operational events, remote authentication and provisioning, usage monitoring, and tool tracking, among others. Combined, these efforts can lead to greater operational efficiencies, reduce wastage and loss, identify potential errors in the production process, and increase worker satisfaction. Infineon's solutions can provide easy integration of Bluetooth® with the control subsystem, simplifying deployment of connected tools.



## Personnel, Visitor, and Worker Safety Monitoring

An RTLS is commonly deployed to enhance the safety of staff and visitors. Staff can be equipped with badges, clothing, or other devices that can be tracked in real time to identify their location in remote environments or emergency response situations; for example, if they have stopped moving or have fallen, entered a restricted or hazardous area, or are in close proximity to a moving vehicle. These solutions can also help enable contact tracing or to enforce social distancing, and enable more automated and accelerated employee congregation.

Other Bluetooth® wearables and portable devices can be leveraged for safety applications. For example, portable LE gas detectors and worker safety devices can be paired to smartphones to provide threat readings, alarms, man-down status, compliance status, worker location, and other information remotely via a dedicated app. This is particularly vital in remote work areas where there may not be any RTLS or other connectivity infrastructure, allowing organizations to respond quickly and effectively to any safety-related incidents. Bluetooth®-enabled panic and SOS buttons can also be paired to smartphones to ensure personnel safety across a wide range of environments, including healthcare, commercial building, and hospitality.



## Supply Chain Monitoring

Other enterprise use cases for Bluetooth® can help identify new operational efficiencies and better traceability across the supply chain. Example products include Bluetooth® LE dataloggers for cold chain monitoring across the transportation network. These devices can help improve visibility of temperature, humidity, and movement across the entire product journey, providing notifications when goods have exceeded their pre-defined limits, identify any issues or bottlenecks in the transportation of goods, address problems in real time to reduce wastage, and meet new regulatory compliance requirements. Sensor tags can relay information via Bluetooth® to cellular-connected wireless gateways in the vehicle or via smartphone and tablet devices for instant cloud monitoring.



## Connected Agriculture and Outdoor Asset Tracking

Bluetooth® can also be leveraged in conjunction with cellular, Low-Power Wide Area Network (LPWAN), and Global Navigation Satellite System (GNSS) technologies to enable localized mesh or extended range networks for remote tracking and monitoring of agricultural assets such as livestock. For example, cattle can be equipped with low-power Bluetooth® ear or collar tags to monitor their temperature and location, helping deter theft and identify any welfare issues. This can be combined with Bluetooth® proximity beacons deployed at certain choke points or feeding areas to monitor their location on a regular basis. Farmers can also interact locally with the tags directly via their smartphone when near an animal to check their location and health history. Long-range Bluetooth® technology can play a vital role in enabling these use cases. Meanwhile, many cellular and LPWAN asset tracking solution providers are increasingly incorporating Bluetooth® LE into their devices to enable seamless indoor and outdoor tracking, as well as local interaction.



## Indoor Navigation and Proximity Services

In retail environments, Bluetooth® RTLS and positioning systems can be used for indoor navigation and wayfinding and proximity services thanks to their ability to broadcast promotional messages to smartphones and other mobile devices.



## Smart Energy

The transition toward distributed renewable energy generation is transforming the entire energy value chain. However, due to the inherent variability within renewable energy generation, real-time performance monitoring and communication across the entire energy supply chain is required. This includes homes and Multi-Dwelling Units (MDUs), alongside on-site energy systems within commercial and industrial enterprises. To ensure reliable operations at all times, the entire energy value chain, from the grid to the enterprise, increasingly needs to be equipped with sensors and wireless connectivity to ensure more effective visibility of demand and strike generation.

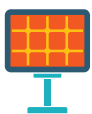

## Solar Photovoltaic Systems

One emerging opportunity for Bluetooth® technology within the energy space is within solar Photovoltaic (PV) energy generation. Solar PV arrays consist of numerous individual modules supplying Direct Current (DC), which needs to be converted to Alternating Current (AC) to be used by the grid. This is achieved by using solar inverters. Increasingly, it is desired to be able to monitor these at the module level in order to provide increased yield. As a result, microinverters are increasingly deployed to enable module-level optimization, monitor the output of each module, provide improved safety, increase installation flexibility, and eliminate single points of failure. These microinverters are now coming equipped with wireless connectivity technologies such as Bluetooth® to offer remote diagnostics, provide support for rapid shutdown, identify performance concerns, simplify installation and repair, and enable firmware updates, among other benefits.



## Battery Energy Storage Systems

An opportunity related to the above is the need for a Battery Energy Storage System (BESS) to circumvent some of the challenges brought about by unpredictable energy generation from renewable sources such as solar. Bluetooth® monitoring devices can provide enhanced visibility of battery capacity, while monitoring their performance and ensuring any potential issues are identified as soon as possible. Using wireless technologies can help streamline the design process, reduce complexity, simplify installation, and provide easier maintenance and support. Innovations such as these will be key to energy storage systems becoming a more critical part of energy networks over the next decade.



## Connected EV Charging Infrastructure

Global Plug-in Electric Vehicle (PEV) sales are expected to reach 70 million in 2035, accounting for 65% of total vehicle sales. The vast majority of PEVs will be fully electric. This will accelerate demand for both home and public EV charging infrastructure. Wireless connectivity technologies such as Bluetooth® and Wi-Fi have the potential to enable connected charging EV platforms that can provide valuable information and services to end users whether at home or using public charging infrastructure when on the road. For example, embedded Bluetooth® can enable communication between the charging point and an app on the user's smartphone. This can provide the end user with information and notifications on the charging status, enable payment services, select customized charging profiles, control charging remotely, and provision charger access, among other use cases. Service providers can enable performance, diagnostics, and even firmware updates remotely. These mobile applications can also help enable smart charging platforms by providing users with information on ideal charging strategies based on the best charging time and rate.



## Smart Retail

Brick-and-mortar retailers are facing a number of growing pressures. This includes store closures and declining traffic, increased online competition and declining brand loyalty, high inflation and energy costs, high staff turnover and labor shortages, the emergence of new fulfillment methods and omnichannel alignment, and the need to operate more sustainably. Bluetooth® technology has the potential to address many of these challenges as retailers increasingly look to smart retail IoT technologies to help them deliver operational efficiencies, increase conversion, and encourage customers to return to stores.



## Electronic Shelf Labels

ESLs are wireless, battery-powered e-paper displays that provide pricing information, product details, inventory and stock-levels, offers and promotions, and other contextual information and features. ESLs have the potential to address many of the challenges facing retailers and become a fundamental component of the future of retail store digitization. For example, ESLs can help enable more accurate pricing via automatic updates, ensure omnichannel pricing alignment to increase in-store conversion, and offer dynamic pricing for price matching, improved inventory management, and reduced wastage. They can also provide better customer experiences by providing extra product and stock information, and monitoring traffic around certain products or in-store locations, allowing retailers to better optimize store and product layouts. When combined with Bluetooth® proximity services and mobile devices, or LED-equipped labels, ESLs can help guide customers to the next item on their list, provide tailored proximity-based promotional offers or upsell recommendations, and provide price checks versus the competition. On the operational side, ESLs can enable retailers to accurately track inventory levels in real time,

ensuring faster replenishment and better control of pricing. LED-equipped ESLs can light up to help staff more efficiently pick online orders, accelerate replenishment, facilitate returns, and reduce mistakes. From a sustainability perspective, ESLs can help reduce food or perishable item wastage via dynamic pricing or expiry date alerts to help clear stock. ESLs can also provide additional sustainability information (e.g., recycling, carbon footprint, energy rating, and sourcing information) to enable better supply chain transparency and foster more responsible purchasing.

ABI Research expects ESLs to become a fundamental component of future retail store digitization. However, as successful large-scale smart retail deployments increasingly rely on interoperability, information gathering, and sharing across many different use cases, retailers will need to avoid siloed solutions that cannot work effectively with each other, looking increasingly toward open and modular platforms enabled by open standards. ESLs can become just one part of a wider smart retail wireless network that is able to aggregate and analyze data from several different use cases and devices to generate more intelligent insights and services.

In early 2023, the Bluetooth® SIG announced the release of the new wireless standard for the ESL market. The intention was to create a scalable, low-power, secure ESL standard that can enable the ESL market to reach its full potential. The Bluetooth® ESL standard leverages key new feature enhancements introduced in Bluetooth® Core Specification Version 5.4, including PAWR and Encrypted Advertising Data, to deliver secure and scalable ESL deployments required by the market. Alongside retail spaces, warehouses, logistics, and industrial settings are increasingly turning toward ESLs to digitize management of traditional paper processes. This can include order picking, inventory management, and parts replenishment. This can help enable more automated compliance within production environments, while improving the efficiency, accuracy, and visibility of production lines and logistics operations.



## Loss Prevention

Some retailers are turning to Bluetooth® technology in order to reduce instances of theft of high-value items within their stores. Companies like Home Depot have trialed using Bluetooth® to enable Point of Sale Activation (POSA) via Bluetooth® locks. Unless activated at a register, stolen items such as power tools are not able to function correctly. Meanwhile, other solution providers have put loss prevention tags on products that can provide additional product information and enable self-checkout via a mobile device, while helping prevent theft.



# MARKET OPPORTUNITIES FOR INDUSTRIAL BLUETOOTH®

Chart 1 shows the growing opportunities for Bluetooth® technologies within industrial settings. Combined, the market is expected to achieve a Compound Annual Growth Rate (CAGR) of 34% between 2023 and 2028, growing from 143 million annual unit shipments in 2023 to over 611 million by 2028.

**Chart 1: Bluetooth®-Enabled Industrial Device Shipments by Market Segment  
World Markets: 2022 to 2028**

(Source: ABI Research)

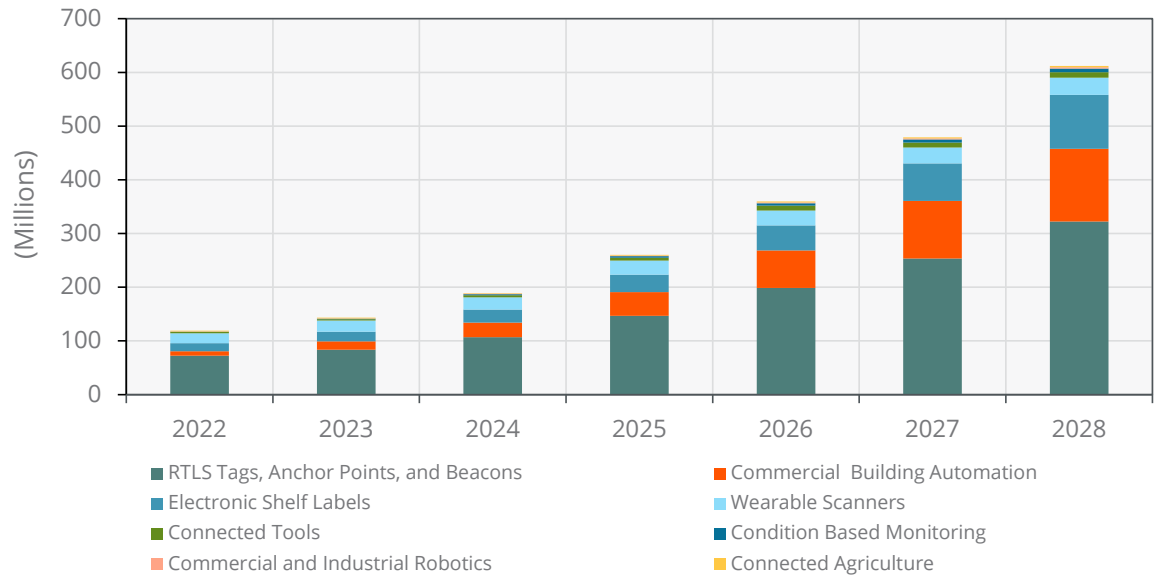

RTLS and asset tracking will represent the largest opportunity at this time thanks to the availability of low-cost, Bluetooth® LE tags that are capable of providing high-accuracy location services across a number of enterprises. Annual shipments of RTLS solutions will reach more than 322 million annual unit shipments by 2028 as scalable deployments of RTLS technology increase.

The second largest market will be the commercial building automation market, which is expected to grow from just 8.5 million units in 2022 to reach over 135 million annual unit shipments by 2028. This will represent the fastest growth market, achieving a 55% CAGR between 2023 and 2028. Driven by the continued adoption of Bluetooth® mesh, thanks to the arrival of the NLC standard, Bluetooth® light switches and lighting fixtures will be the fastest growing areas, achieving a CAGR of over 100% during the next 5 years. Rapid growth of Bluetooth®-enabled access control readers and a range of wireless sensor devices will propel the Bluetooth® building automation market even further forward.

The ESL market is on the verge of accelerated adoption across multiple regions. This will be driven by deeper penetration in existing regions and organic growth in areas such as Asia-Pacific, the United States, the United Kingdom, and other parts of Europe. Numerous compounding pressures on retailers are forcing a smart retail transformation built upon IoT Technologies. By 2028, ABI Research forecasts that total Bluetooth® ESL shipments will reach over 100 million annual unit shipments. This is due in large part to the arrival of PAwR and the Bluetooth® ESL standard, which will help enable the next wave of adoption and deliver an interoperable smart retail solution to address both consumer-facing and back end operational challenges as they arrive.

Other high-growth markets include Bluetooth® condition monitoring devices, including industrial sensor nodes. These will grow to 7 million annual unit shipments by 2028 as awareness and availability of these solutions grow. Similarly, connected tools will reach nearly 10 million annual unit shipments by 2028, consisting of a mixture of embedded solutions and retrofit tags that can be attached to existing tools. Other emerging sectors discussed in this whitepaper may also reach significant volumes over the next 5 years, including solar microinverters, EV charging infrastructure, energy storage systems, supply chain monitoring, and outdoor asset tracking. Furthermore, due to the flexibility of Bluetooth® technology, new device categories that can help transform industrial operations are likely to continue to emerge over the next decade.



## KEY REQUIREMENTS FOR INDUSTRIAL BLUETOOTH®

As the previous section highlights, there is an enormous range of opportunities for Bluetooth® technology across the IIoT. This breadth of applications brings a diversity of requirements and priorities. Most applications will need to strike a balance between several metrics to maximize their flexibility and utility across several types of industrial environments. When designing a Bluetooth® solution for the industrial space, product designers should look toward portfolios that can address these requirements and offer flexible, tailored solutions that can maximize performance and battery life, ensure reliability, security, and interoperability, and be deployed swiftly without compromise. Infineon's portfolio of industrial Bluetooth® solutions is capable of addressing all of the major industrial requirements, including the following:

- **Ultra-Low Power Consumption:** Some Bluetooth® use cases will heavily prioritize ultra-low power consumption in order to be able to support multi-year battery life. This will help reduce labor and maintenance costs, while enabling deployment in locations where wired connectivity is difficult or costly to deploy.
- **Robust RF Performance:** Other Bluetooth® devices will be deployed in very harsh industrial environments with heavy potential for interference and obstacles. The priority will likely be high RF performance, optimizing the Signal-to-Noise Ratio (SNR) for increased robustness and reliability. This will include increased transmit power and receive sensitivity, as well as interference mitigation techniques in crowded, congested RF environments.
- **Support for Higher Throughput:** Some use cases will require support for higher 2 Mbps throughput modes in order to better support firmware updates or the transfer of higher resolution data.

- **Mesh or Broadcast Topologies:** Large-scale deployments of sensors, tags, microinverters, and labels may require a combination of connectionless one-to-many PAWR topologies or Bluetooth® mesh implementations depending on the specific deployment scenario.
- **Extended Range Capabilities:** Deployments in large campus environments or outdoor settings may require long distances between gateways and end node devices to effectively monitor assets, livestock, and equipment. Bluetooth® solutions that can provide ranges of 1km to 2 km will be essential for many of these deployments and entire facility monitoring.
- **Multi-Protocol Integrated Circuits (ICs):** Other solutions may require multiple technologies to achieve their goals. Combo ICs that integrate Bluetooth® and other technologies such as Wi-Fi or 802.15.4 may be vital in certain use cases that require direct smartphone connectivity, or within IoT gateways where Wi-Fi is used to aggregate vast amounts of sensor data from multiple Bluetooth® LE sensor nodes.
- **High Security:** Mission-critical and safety-related processes are being managed via wireless connectivity, making security another top priority when choosing what technology or solution to deploy within commercial and industrial environments. Solutions that can combine robust connectivity with hardware-based security features will be essential in addressing these use cases.
- **Low Cost:** For certain applications, keeping the cost down of the connectivity components will be vital in enabling enterprises to deploy their solutions at scale. For example, tracking thousands of assets within a hospital or warehouse or deploying tens of thousands of ESLs across a retailer's portfolio will require low-cost implementations.
- **Small Device Footprints:** Highly integrated solutions with small footprints will be essential in enabling miniaturized sensor devices across a number of applications. This is particularly vital within asset tracking, ESLs, connected tools, and a variety of machine sensors and monitors.
- **Extended Temperature Ranges:** Bluetooth® end node devices will be deployed across a wide range of environments with varying temperatures. This could include lower temperatures within refrigeration units for cold chain monitoring or on moving machinery within high-temperature industrial environments. Support for extended temperature ranges will be vital to enabling reliable and robust performance across the widest range of enterprise scenarios.



## HOW IS INFINEON'S BLUETOOTH® TECHNOLOGY ENABLING THE IIoT TO REACH ITS TRUE POTENTIAL?

In order to address these diverse requirements effectively, product designers need to be able to leverage Bluetooth® solutions that are more readily tailored to their specific application. While there are numerous Bluetooth® vendors in the market today, a key decision when designing IIoT products is choosing solutions that are optimized for performance within those environments, as well as those that can be deployed into market in a timely and cost-effective manner.

Infineon is a market leader in Bluetooth® and other wireless IoT connectivity technologies, shipping hundreds of millions of Bluetooth® solutions annually. Its AIROC™ Bluetooth® portfolio consists of a number of Bluetooth® PSoCs™ (programmable SoCs), combo and multi-protocol SoCs, and connectivity modules, all of which are capable of addressing the varied IoT applications listed above, while streamlining the development and design processes. These solutions are also equipped with a mature software stack that is highly interoperable with deployed devices.

---

**Infineon is a market leader in Bluetooth® and other wireless IoT connectivity technologies, shipping hundreds of millions of Bluetooth® solutions annually.**

---

Infineon's diverse AIROC™ Bluetooth® portfolio can be segmented into five main areas: the Bluetooth® and Bluetooth® LE Dual-Mode SoC Family, the Bluetooth® LE SoC Family, the Bluetooth® LE & Multi-protocol SoC Family, its Wi-Fi & Bluetooth® Combo solutions, and its module solutions. Within these product families come a varied range of solutions with their own unique performance advantages.

The most recently announced product in the portfolio is the AIROC™ CYW20829 Bluetooth® LE-connected Microcontroller Unit (MCU). This solution supports the Bluetooth® 5.4 specification, including support for PAWR to enable emerging ESL and other large-scale sensor network deployments. Thanks to its excellent link budget, the solution is capable of operating reliably in a wide range of commercial and industrial environments, while also supporting ranges of up to 2.3 km. This is the longest in the industry without the need for an external power amplifier. In addition, secure boot, TRNG, eFuse for custom keys, and cryptography acceleration promise high security. Support for Bluetooth® mesh, LE 2 Mbps, and Direction Finding make it an extremely versatile solution that can address a wide variety of some of the most stringent emerging enterprise applications. Meanwhile, the connected MCU approach enables ultra-low power consumption and simplified integration into product designs.

Alongside the newly launched CYW20829, Infineon has an extensive portfolio of Bluetooth® LE-only and dual-mode Bluetooth® 5.x solutions that can provide ultra-low power consumption, strong RF performance, and extended range support. Notable examples include the AIROC™ CYW20819/CYW20820/CYW89820 Dual-mode Bluetooth® SoCs, ideal for continuous monitoring and data transfer applications within healthcare, industrial, robotics, EV charger, and smart building settings.

For additional flexibility, Infineon's AIROC™ CYW30739 Bluetooth® LE module and 802.15.4 SoC can enable scalable use cases that combine the best of both technologies and provide wider system interoperability. This is particularly vital in smart building and NLC applications with large-scale mesh networks. Bluetooth® can also be used to provision devices or offer direct connectivity to mobile devices for control and configuration purposes, while taking advantage of 802.15.4 mesh solutions. Meanwhile, the CYW20835 Bluetooth® LE SoC provides strong RF performance and an integrated power amplifier for reliable lighting, building automation, and industrial sensor nodes.

Additional connected MCU solutions such as the PSoC™ 63 with AIROC™ Bluetooth® LE provides high security and performance for use within access control, connected tools, smart energy, medical, and robotics applications, while the PSoC™ 4 with AIROC™ Bluetooth® LE provides ultra-low power consumption, which is ideal for sensor nodes.

Lastly, for higher throughput, always-on, or lower latency applications, Infineon’s AIROC™ Wi-Fi & Bluetooth® Combo solutions can enable additional applications within industrial settings such as scanning devices, POS terminals, wearable devices, smart displays, robotics, machine connectivity, high-performance sensors, and video-related applications.

Infineon’s Bluetooth® portfolio also consists of a number of pre-certified System-in-Package (SiP) modules. As Figure 2 demonstrates, the design cycle of Bluetooth® solutions, particularly in more stringent commercial and industrial environments, can be lengthy and complex. This often requires multiple phases of tuning, testing, and reconfiguration, prior to any regulatory compliance testing.

**Figure 2: Reducing Design Complexity with Bluetooth® Modules**

(Source: Infineon)

**Simplified Bluetooth® RF Design Flow**

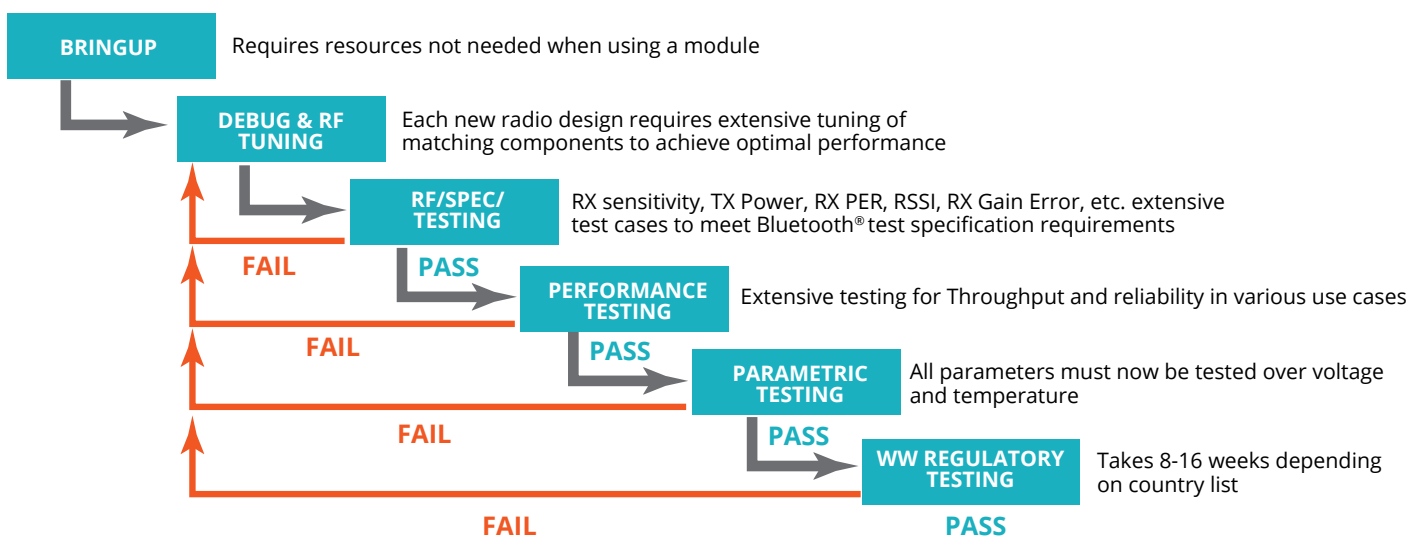

**Infineon AIROC™ Bluetooth® Modules reduce the risk and minimize time-to-market**

At each stage in the design cycle, there is potential for failures that can cause further delays and complications. The availability of pre-certified modules such as Infineon’s AIROC Bluetooth® and Bluetooth® LE portfolio can significantly reduce the cost and complexity of the design cycle, speeding up the time to market, and providing guaranteed performance that is tailored to specific industrial and commercial use cases. For example, Infineon offers modules that cater to small form factors, support external antennas, provide extended range Bluetooth® connectivity, and provide extended operating temperature. Product designers can select the optimal solution for their application and take advantage of Infineon’s AIROC™ Bluetooth® Software Development Kit (SDK) in ModusToolbox™ with code examples to further ease the development of IoT applications. The table following highlights IIoT market verticals, use case requirements and specific module solutions from Infineon’s product portfolio.

**Table 1: Infineon's Portfolio of Products Can Address Evolving Requirements of the IIoT**

(Source: ABI Research)

Market Vertical	Key Device Types	Use Case Requirements	Optimized Infineon Solutions (MCU/SoC)	Optimized Infineon Solutions (Modules)
Industrial	Industrial Sensors	Robust RF performance	CYW20829	CYW20829 Module
		Ultra-low power consumption	PSoC63	PSoC63 Module
		Broadcast/PaWR support		
		Support for higher throughput		
		Extended range		
		High security		
Extended temperature range				
Industrial	Robotics	Robust RF performance	CYW20829	CYW20829 Module
		Support for higher throughput	PSoC63	CYW20822 Module
		Extended range		PSoC63 Module
		High security		
		Extended temperature range		
Industrial	Human-Machine Interfaces (HMIs)	Robust RF performance	CYW20829	CYW20829 Module
		Support for higher throughput	PSoC63	CYW20822 Module
		High security		PSoC63 Module
		Extended temperature range		
Industrial	Connected Tools	Robust RF performance	CYW20829	CYW20829 Module
		Extended range	PSoC63 (CSP)	CYW20822 Module
		Small footprint		PSoC63 Module
		Extended temperature range		
Industrial	Industrial Computing Devices, Scanners, and Wearables	Robust RF performance	CYW20829	CYW20829 Module
		Support for higher throughput	PSoC63	CYW20822 Module
		Extended range	CYW20706	PSoC63 Module
		Extended temperature range		CYW20706 Module
Industrial	IIoT Gateways	Robust RF performance	CYW20829	CYW20829 Module
		Ultra-low power consumption	PSoC63	CYW20822 Module
		Support for higher throughput		PSoC63 Module
		Mesh support		
		Broadcast/PaWR support		
		Extended range		
		High security		
Extended temperature range				
Smart Building	Wireless Sensor Networks	Robust RF performance	CYW20829	CYW20829 Module
		Ultra-low power consumption	PSoC63	CYW20822 Module
		Mesh support		PSoC63 Module
		Broadcast/PaWR support		
		Extended range		
		High security		
		Small footprint		

(Table continues on the following page)

Market Vertical	Key Device Types	Use Case Requirements	Optimized Infineon Solutions (MCU/SoC)	Optimized Infineon Solutions (Modules)
Smart Building	Smart Lighting	Robust RF performance	CYW20829	CYW20829 Module
		Mesh support	PSoC63 (CSP)	CYW20822 Module
		High security		PSoC63 Module
		Small footprint		
		Extended temperature range		
Smart Building	Access Control	Extended range	CYW20829	CYW20829 Module
		High security	PSoC63 (CSP)	CYW20822 Module
		Small footprint		PSoC63 Module
Asset Tracking, RTLSs, and Supply Chain Monitoring	Asset Tags	Robust RF performance	CYW20829	CYW20829 Module
		Ultra-low power consumption	PSoC63	CYW20822 Module
		Broadcast/PaWR support	CYW20706	PSoC63 Module
		Extended range		CYW20706 Module
		Small footprint		
Asset Tracking, RTLSs, and Supply Chain Monitoring	Anchor Points and Gateways	Robust RF performance	CYW20829	CYW20829 Module
		Support for higher throughput	PSoC63	CYW20822 Module
		Mesh support		PSoC63 Module
		Broadcast / PaWR support		
		Extended range		
Asset Tracking, RTLSs, and Supply Chain Monitoring	Worker Safety	Robust RF performance	CYW20829	CYW20829 Module
		Extended range	PSoC63	CYW20822 Module
		High security		PSoC63 Module
		Small footprint		
		Extended temperature range		
Asset Tracking, RTLSs, and Supply Chain Monitoring	Supply Chain Monitoring	Robust RF performance	CYW20829	CYW20829 Module
		Ultra-low power consumption	PSoC63	CYW20822 Module
		Small footprint	CYW20706	PSoC63 Module
		Extended temperature range		CYW20706 Module
Asset Tracking, RTLSs, and Supply Chain Monitoring	Connected Agriculture and Outdoor Asset Tracking	Robust RF performance	CYW20829	CYW20829 Module
		Ultra-low power consumption	PSoC63	CYW20822 Module
		Mesh support	CYW20706	PSoC63 Module
		Broadcast/PaWR support		CYW20706 Module
		Extended range		
Asset Tracking, RTLSs, and Supply Chain Monitoring	Proximity Beacons	Ultra-low power consumption	CYW20829	CYW20829 Module
		Broadcast / PaWR support	PSoC63	CYW20822 Module
		Small footprint	CYW20706	CYW20706 Module
		PSoC63 Module		

(Table continues on the following page)

Market Vertical	Key Device Types	Use Case Requirements	Optimized Infineon Solutions (MCU/SoC)	Optimized Infineon Solutions (Modules)
Smart Energy	Solar Photovoltaic Systems	Robust RF performance	CYW20829	CYW20829 Module
		Mesh support	PSoC63	CYW20822 Module
		Broadcast/PaWR support		PSoC63 Module
		Extended range		
		High security		
		Small footprint		
		Extended temperature range		
Smart Energy	Energy Storage Systems	Robust RF performance	CYW20829	CYW20829 Module
		Mesh support	PSoC63	CYW20822 Module
		Broadcast / PaWR support		PSoC63 Module
		Extended range		
		High security		
		Small footprint		
		Extended temperature range		
Smart Energy	Connected EV Charging Infrastructure	Robust RF performance	CYW20829	CYW20829 Module
		Support for higher throughput	PSoC63	CYW20822 Module
		Extended range		PSoC63 Module
		High security		
Smart Retail	Electronic Shelf Labels	Robust RF performance	CYW20829	CYW20829 Module
		Ultra-low power consumption	PSoC63	CYW20822 Module
		Broadcast/PaWR support		PSoC63 Module
		Extended range		
		High security		
		Small footprint		
Smart Retail	Loss Prevention	Robust RF performance	CYW20829	CYW20829 Module
		Ultra-low power consumption	PSoC63	CYW20822 Module
		Broadcast/PaWR support		PSoC63 Module
		Extended range		
		High security		
		Small footprint		



## KEY TAKEAWAYS

The IoT is increasingly at the forefront of digital transformation within commercial and industrial enterprises, as they look to face and combat myriad challenges today and over the next decade. Wireless connectivity technologies such as Bluetooth® are becoming increasingly vital in this process, enabling a whole host of benefits, including enhanced operational efficiencies, continuous process visibility, and safer and more automated working environments, among many others. As has been demonstrated, this consists of a growing number of applications, each with its own specific requirements and priorities. As this diversity increases, it becomes clear that there is no one-size-fits-all connectivity solution. This is accelerating the need for specialist Bluetooth® solutions that are not only tailored toward solving specific enterprise problems, but are also cost-effective and can be swiftly integrated into product designs. Thanks to Bluetooth's continued innovation at the standards level, the technology is increasingly capable of solving more of the ever-changing enterprise demands. The wide availability of Bluetooth® chipsets and modules from companies like Infineon can maximize these new features, while providing unique application-specific benefits to maximize performance and ROI, which will be vital in opening up enormous new opportunities for IoT solution providers. These solutions will pave the way to fully realize the transformative benefits of the commercial and industrial IoT.



Published November 2023  
157 Columbus Avenue  
New York, NY 10023  
Tel: +1 516-624-2500  
[www.abiresearch.com](http://www.abiresearch.com)

## **ABOUT ABI RESEARCH**

ABI Research is a global technology intelligence firm delivering actionable research and strategic guidance to technology leaders, innovators, and decision makers around the world. Our research focuses on the transformative technologies that are dramatically reshaping industries, economies, and workforces today.

©2023 ABI Research. Used by permission. ABI Research is an independent producer of market analysis and insight and this ABI Research product is the result of objective research by ABI Research staff at the time of data collection. The opinions of ABI Research or its analysts on any subject are continually revised based on the most current data available. The information contained herein has been obtained from sources believed to be reliable. ABI Research disclaims all warranties, express or implied, with respect to this research, including any warranties of merchantability or fitness for a particular purpose.